

# 440.3.608

## Vacuum cleaner motor performance

# DOMEL®

Vacuum cleaner motors with high efficiency 440.3.608 / 1800W / 230V / 50Hz are used for dry aspiration. Technical data and dimensions are given in the table. Vacuum motors consist of universal commutator motor and single fan stage. The rotor is supported with two ball bearings enabling vertical or horizontal installation of motor. The motor is designed for insulation class 200K and constructed according to EN 60335-1.

### Technical data:

|                         |               |        |               |                            |
|-------------------------|---------------|--------|---------------|----------------------------|
| Normal operation:       | $P_m$         | $\geq$ | 1760          | W                          |
| Vacuum:                 | $P_{max}$     | $\geq$ | 29,8<br>119,8 | kPa<br>in H <sub>2</sub> O |
| Air Flow at $\phi 50$ : | $Q_{\phi 50}$ | $\geq$ | 54<br>115     | dm <sup>3</sup> /s<br>CFM  |
| Air Power:              | $P_{2max}$    | $\geq$ | 670           | W                          |
| Efficiency:             | $\eta_{max}$  | $\geq$ | 41            | %                          |
| Mass:                   | $m$           | =      | 1,3           | kg                         |

|                |        |
|----------------|--------|
| Voltage:       | 230 V  |
| Frequency:     | 50 Hz  |
| Nominal Power: | 1800 W |

## Max. power 1850W

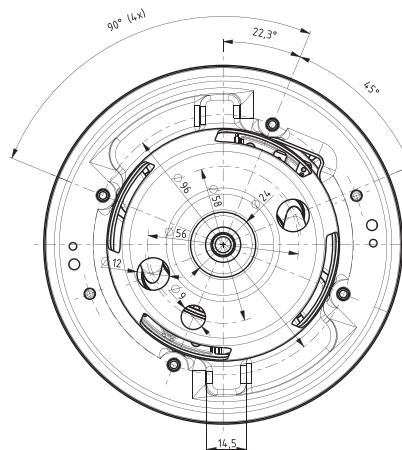
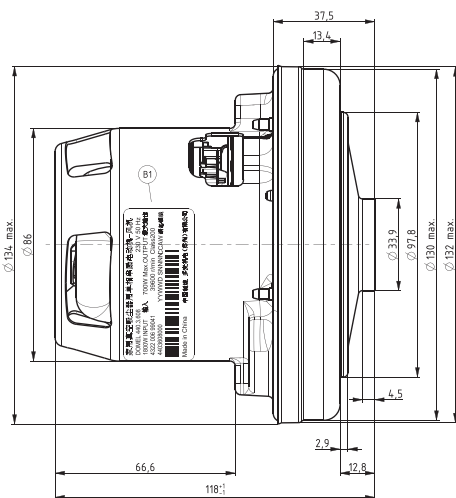

Dimensional and performance data are subject to change without notice.

| Orifice |       | Current | Input Power | Speed             | Pressure |                     | Air Flow           |       | Air power | Efficiency |
|---------|-------|---------|-------------|-------------------|----------|---------------------|--------------------|-------|-----------|------------|
| mm      | in*   | A       | W           | min <sup>-1</sup> | kPa      | in H <sub>2</sub> O | dm <sup>3</sup> /s | CFM   | W         | %          |
| 50      | 2     | 8,20    | 1834        | 39533             | 1,4      | 5,1                 | 57,0               | 121,2 | 82        | 4,5        |
| 40      | 1 1/2 | 8,15    | 1824        | 39636             | 3,3      | 17,4                | 55,3               | 114,8 | 183       | 10,0       |
| 30      | 1 1/8 | 8,01    | 1792        | 40028             | 8,7      | 41,7                | 49,7               | 101,1 | 433       | 24,1       |
| 23      | 7/8   | 7,68    | 1718        | 41084             | 17,0     | 72,6                | 39,9               | 81,0  | 677       | 39,4       |
| 19      | 3/4   | 7,28    | 1632        | 42697             | 22,8     | 91,1                | 31,1               | 66,2  | 708       | 43,4       |
| 16      | 5/8   | 6,87    | 1544        | 44477             | 27,1     | 109,2               | 23,8               | 49,8  | 645       | 41,8       |
| 13      | 1/2   | 6,46    | 1453        | 46490             | 29,5     | 118,5               | 16,4               | 33,3  | 482       | 33,1       |
| 10      | 3/8   | 6,04    | 1358        | 49005             | 30,1     | 120,9               | 9,8                | 19,2  | 295       | 21,7       |
| 6       | 1/4   | 5,54    | 1245        | 51432             | 30,5     | 122,7               | 4,2                | 8,8   | 129       | 10,4       |
| 0       | 0     | 5,14    | 1155        | 53070             | 31,4     | 126,1               | 0,0                | 0,0   | 0         | 0,0        |

Data above represent the performance of an average motor sample. Individual data may vary due to normal manufacturing variations.

\* Orifice in inch is only approximative.